



## StormStation™ - 3000 Litres & 5000 Litres Rainwater Harvesting system

### Product Data Sheet

#### Product Description

The Stormsaver StormStation™ has been designed to provide a self-contained, high quality Rainwater Harvesting system. The unit can be both portable or a permanent installation. The Stormsaver StormStation™ is unique because it is a complete Rainwater Harvesting system combining tank, filters, pumps and controls all in one unit. The StormStation™ is designed simply for plug and play installation. The unit can be offloaded from a delivery vehicle and connected to your appliances with minimum labour requirements and there will be no costly installation for filters, tanks, control units and header tanks located around the building. This all in one unit will save time on installation, save water by using fresh rainwater, save money on your water bills and contribute towards your sustainable goals, whilst assisting with storm water and flood control.

The system can be used in many building types and is suited to both new build and retrofit projects where the above ground StormStation™ can be located in close proximity to the building.

It is suitable for:

- Retro fit to existing sites
- Commercial vehicle forecourts - Vehicle wash
- Service station sites
- Temporary buildings
- Commercial offices or industrial units
- Permanent buildings requiring a packaged system

Stormsaver Ltd. T 01636 815254  
 Hockerton Moor Enterprise Park e enquiries@stormsaver.com  
 Winkburn Lane | Hockerton f Like us on facebook  
 Newark | Nottinghamshire t Follow us on twitter  
 NG22 8FL

#### Applications

The StormStation™ system can provide filtered rainwater for a wide range of applications:

- Toilet and urinal flushing
- Vehicle washing
- Cleaning and wash down
- Laundry
- Plant watering and irrigation\*
- As well as other applications such as industrial process use

\*A drip irrigation system may require a special layout in combination with an expansion vessel

#### Location

Designed for installation external to a building. Ideally the system should be located close to down pipes to collect water from the roof area. In certain sites the unit can be installed inside a building e.g. large warehouse units

- The unit should be installed on a suitable flat concrete base capable of supporting the tank and lid together with the weight of the water at full capacity and associated pipework
- The unit requires access for maintenance with a minimum of 1000mm above, 1000mm in front of the door and a minimum of 450mm to each side for connection of pipework
- All tanks should be installed on to a level and flat base which must not deviate by more than 2mm in length under a 1000mm nominally plane straight edge
- Levelling steels are recommended for bases over 4m

#### Services

This system supplies a direct, pressurised supply of water to appliances using a booster pump. During periods of low rainfall, a supply of mains water is used to top up the system via a compliant air break.

The unit will require services for:

- Incoming rainwater supply from the roof
- Tank overflow should be fitted to the storm drain or soakaway
- Control unit emergency warning pipe should be fitted so that the flow of water is visible if overflowing
- Mains electrical supply
- Pressurised rainwater from the system booster pump feed (to points of demand)
- mains water supply for top-up in low rainfall conditions\*

\*During periods of low rainfall, it is important to ensure that mains water pressure and flow rates match the demand of the system.

## Technical Information

The StormStation™ system is manufactured by Stormsaver and will be delivered to site for rapid installation. The unit comes in capacities of 3,000 Litres and 5000 Litres. If greater capacity is required units can be linked or Stormsaver can offer a bespoke solution.

All Stormsaver systems are manufactured and tested by Stormsaver. A full certification is given on completion for warranty purposes.

StormStation Technical Information		
Capacity	3,000 L	5000 L
Dimensions L x W x H (mm)	2000 x 1345 x 2215	3000 x 1345 x 2215
Dry weight	620kg	935kg
Wet weight	3620kg	5935kg
Offloading	The unit is manufactured on a GRP skid to enable the unit to be located by forklift. This enables the unit to be relocated to different sites if it is to be portable	
Colour	RAL 5005 - Royal Blue (Choice of RAL colours as an extra cost option)	
Insulation	50mm sealed within the tank, door and cabinet walls	
Rainwater inlet	Gravity inlet feed 110mm	
Rainwater overflow	Gravity overflow feed with integral skimming overflow device 110mm	
Ladders:	External access ladders are fitted to the side of the tank to access the tank for maintenance. Ladders are steel with zinc plated external coating	
Eyebolts	Eyebolts are fitted to the top of the tank to lock-on the engineers lanyard harness at two points attaching for safety when working at heights	
Services	Services should enter the three specific pad areas designed in the service cabinet wall: base, left and right handed – do not drill any holes into the cabinet walls which could compromise the tank walls or compromise water tightness	
Service cabinet	The service cabinet is accessed via the full size insulated door (fitted with a lock). There is a lamp inside the control cabinet	
Frost protection	Thermostatic heater fitted within control cabinet	

## Pre-tank filter, Inlet calmer, floating suction filter

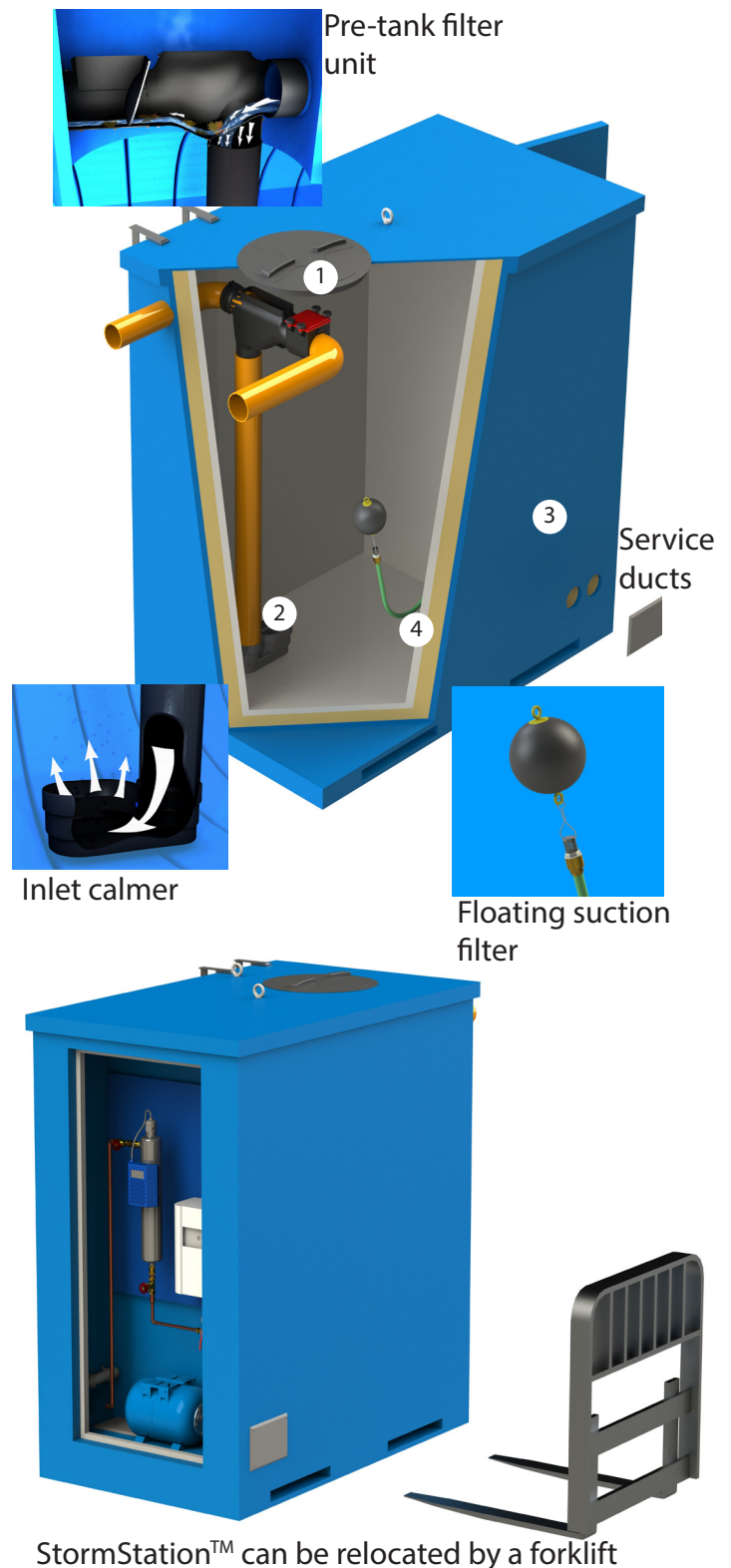

Stormsaver Ltd. T 01636 815254  
 Hockerton Moor Enterprise Park e enquiries@stormsaver.com  
 Winkburn Lane | Hockerton f Like us on facebook  
 Newark | Nottinghamshire t Follow us on twitter  
 NG22 8FL



## Technical Drawing

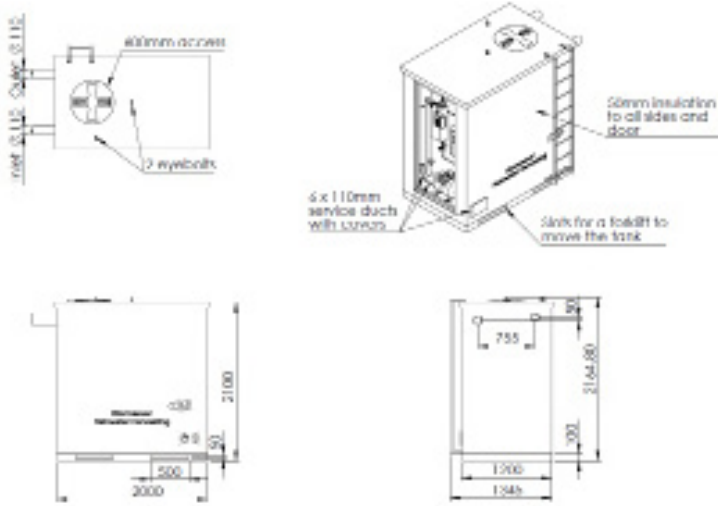

## Pre-tank filter and inlet calmer

The pre-tank filter removes leaves and other debris and is integrated within the tank to meet BS EN 16941-1:2018. The filtered rainwater enters the tank via an inlet calmer to prevent incoming water disturbing sediment on the base of the tank. This filter is accessed via a cover in the tank lid and is designed to filter rainwater coming from building roofs. The filter comes complete with non-return valve, preventing water from flowing back up into the tank whilst also preventing small animals from entering the tank.

The filter itself uses a stainless-steel wedge wire, with a gap width of 800 microns and reliably filters the contaminants. Its trapezoidal shape and diagonally set profile prevents the dirt from settling and clogging it. During heavy rainfall this design also means the filter is self-cleaning, which reduces maintenance requirements. The sturdy stainless steel filter is designed to last the life of the filter.

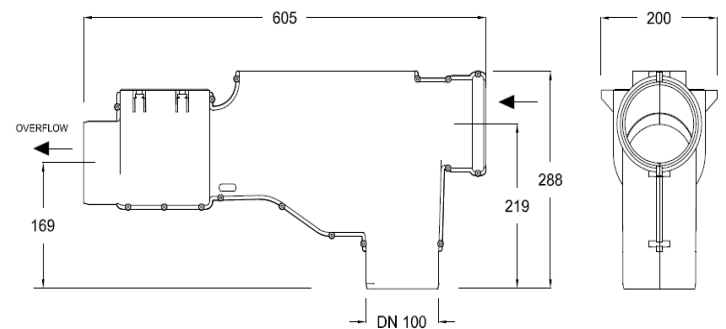

Pre-tank filter installed within tank



## Tank specifications and conformity

The tank is designed at optimum capacity for your roof area and demand of the building. Tank and housing are manufactured using high quality glass reinforced plastic (GRP) incorporating a Lloyds approved resin system that meets EN 14118-1:200 and ISO2599-1980-GLASS and manufactured using materials approved by WRAS

The tank housing is designed with the parameter and principles of EN13280:2001 and BS EN 16941-1:2018 GRP coated with orthophthalic BS3532 & BS2782 gel coat finish.

Tank materials are UV stabilised for external use  
Internal fittings: stainless steel

## Pipework connections

Connections	3000L	5000L
RainWater Inlet (roofwater)	110mm	110mm
RainWater Overflow (storm)	110mm	110mm
Potable water pipe	1" BSP	1" BSP
Discharge pipework	3/4" BSP	1" BSP

Stormsaver Ltd. T 01636 815254  
 Hockerton Moor Enterprise Park e enquiries@stormsaver.com  
 Winkburn Lane | Hockerton f Like us on facebook  
 Newark | Nottinghamshire t Follow us on twitter  
 NG22 8FL



## Technical Details

Technical details	StormStation™ Booster:10	StormStation™ Booster:20	StormStation™ Booster:40
Power supply in	110-230V AC / 50-60 Hz	230 V AC / 50-60Hz	230 V AC / 50-60Hz
Power consumption	90W / 4A	0.8kW	1.25kW
Current	4A	4A	4A
Max. working pressure	2.5 – 3.5 bar	2.0 – 4.5 bar (adjustable)	2.0 – 5.5 bar (adjustable)
Max. flow	10 L/min	80 L/min	110 L/min
Primary pressure	2.5 – 4 Bar (Mains Supply)	2.5 - 6 bar (Mains Supply)	2.5 - 6 bar (Mains Supply)
Pump start pressure	1.8 – 2.5 bar (adjustable)		
Protection class	IP 54	IP 54	IP 54
Max. application height above control unit	8 Metres*	10m*	15m*
Application	Low flow rates such as a single toilet flush systems  Not suitable for irrigation systems or commercial vehicle wash.	Toilets, washing machines, external taps in line with the maximum flow of 80Litres / minute**	Toilets, washing machines, external taps in line with the maximum flow of 110Litres / minute**

\*Ensure that toilets, washing machines or other applications are not above the maximum application level

\*\*A drip irrigation system may require a special layout in combination with an expansion vessel

Please ensure that you select the correct Booster unit for your flow requirement.

Any queries please contact Stormsaver Technical support 0844 884 0015

### StormStation™ Booster 10 Capabilities (Head)

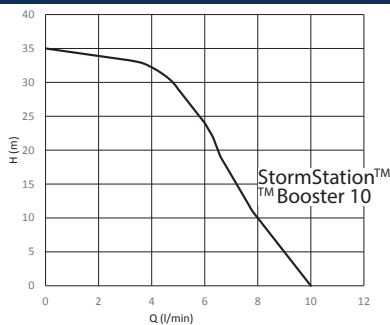

### StormStation™ Booster 20/40 Pump Capabilities

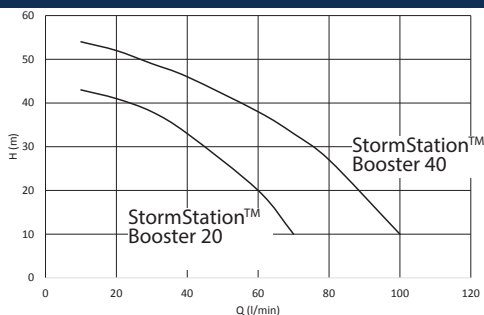

### Optional Extras

Option	Details
Ladder hoops	Ladders can be fitted with hoops to gain access to the top of the tank for maintenance.
Handrails	Either part or full peripheral handrails can be added around the top of the tank.
Colour / Branding	RAL 5005 - Royal Blue (Choice of RAL colours as an extra cost option)
Branding	Optional cost extra to brand the unit to suit clients site
UV	Optional, unless unit is for irrigation or vehicle wash

All optional extras are available at an additional rate.  
BMS and monitoring unit not available on this system.

Stormsaver Ltd. T 01636 815254  
 Hockerton Moor Enterprise Park e enquiries@stormsaver.com  
 Winkburn Lane | Hockerton f Like us on facebook  
 Newark | Nottinghamshire t Follow us on twitter  
 NG22 8FL

